

# PETIT PISTON MUR – WALL LIGHT

## SOLID CRAFTED GLASS CYLINDER WITH COOLING SOCKET, HIGH-POWER LED AND BACKPLATE

Perfectly shaped design through maximum reduction, the straight frame and the restrained wall bracket with back plate give this wall lamp its character. Since the glass cylinders are handcrafted and each piece is unique, the dimensions vary. The luminaire can be mounted upwards or downwards.

### Technical specifications

Voltage	24 V DC	Colour temperature	2,000–2,700 K
Power	approx. 7 Watts	Weight	approx. 3 kg
Luminous flux / efficiency	100 lm / 14 lm/W	Dimensions (L x W x H)	approx. 80 x 79 x 440 mm

LED modules with various colour temperatures:

“Warm white LED”: 2,500 K, > 90 Ra; “Amber LED”: 2,000 K, > 80 Ra;

“Tuneable white LED”: 2,000–2,700 K (adjustable colour temperature), > 80–>90 Ra.

Lifespan of the LED module: approx. 40,000 hours; can be replaced by electrician.

### Control technology

The light fixture is dimmable with interface for phase cut (trailing edge) dimming, 1–10 V, pushdim, remote control, DALI, or CASAMBI. Dimmer / power supply units have to be installed externally; switches / controllers to be provided by the customer.

### Material

Please select your preferred surface finish for the socket and ceiling bracket in the “Material” section of our website.

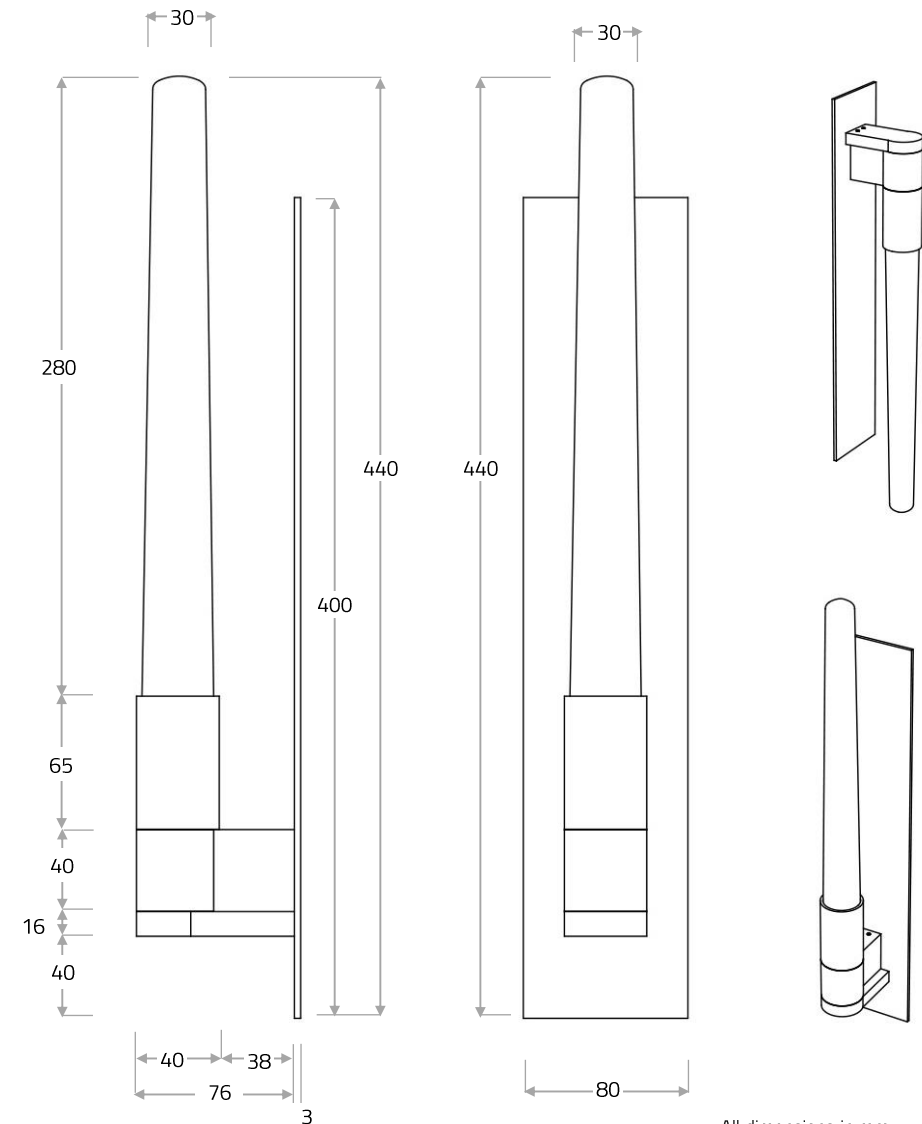

All dimensions in mm



LCB Manufactur GmbH, Eiswerderstr. 16, D-13585 Berlin

MASSIFCENTRAL

Phone +49 (0)30 33 30 80 30 00, info@massifcentral.de, www.massifcentral.de

